

NO.	LOC.	HOW	WAS	DATE	INT.

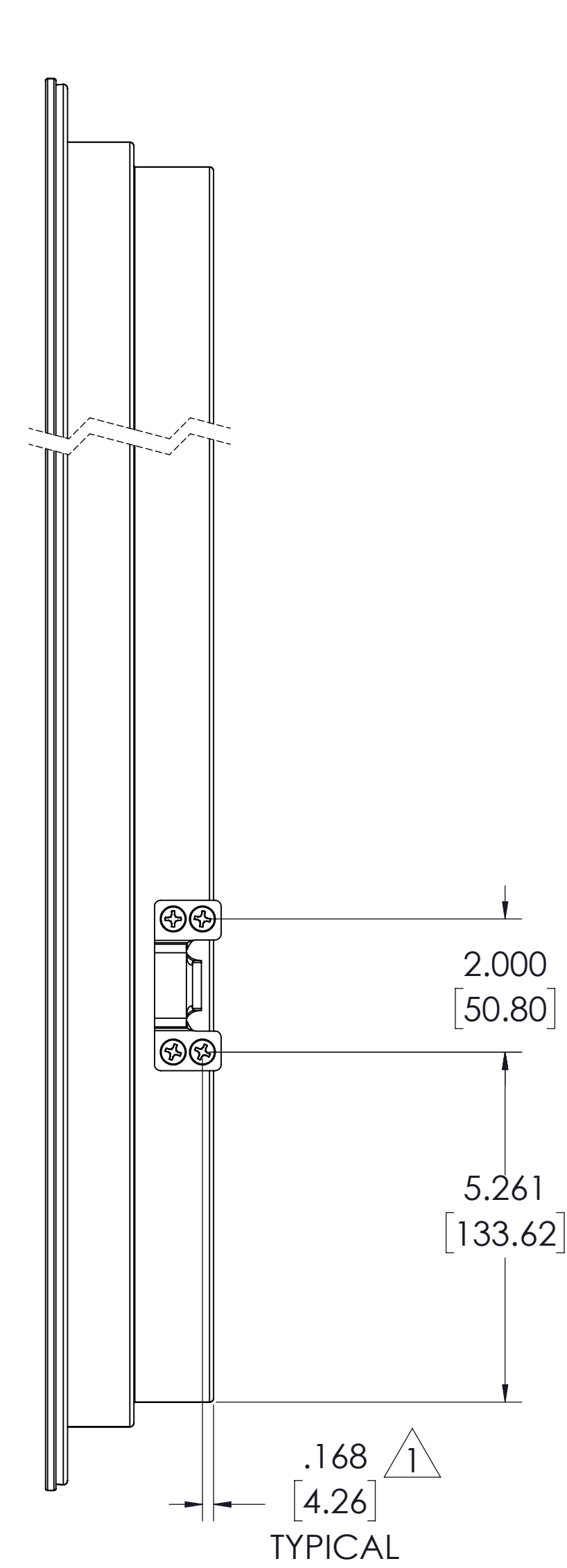

SASH KEEPER LOCATION

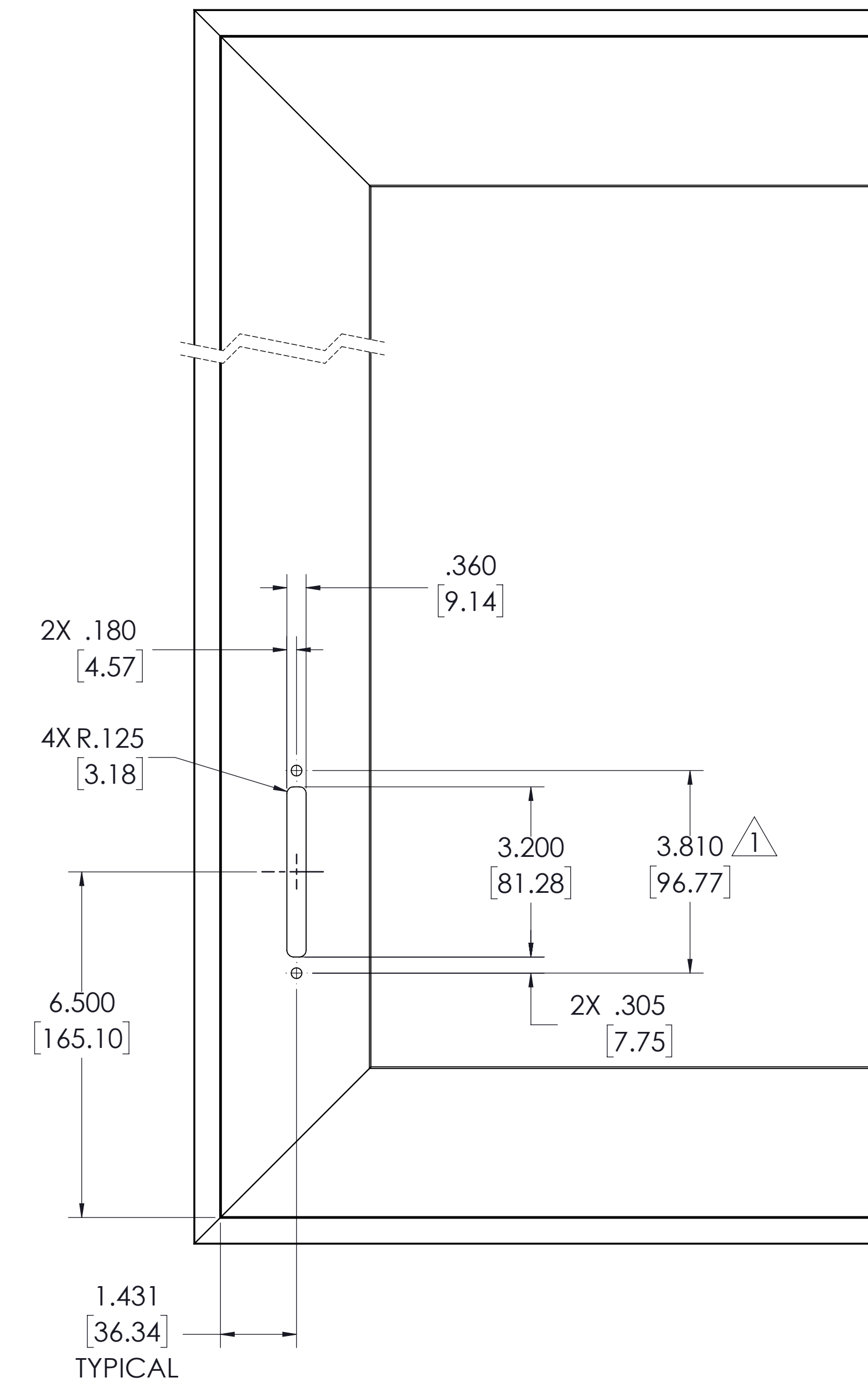

FRAME LOCK DRIVE CUT-OUT

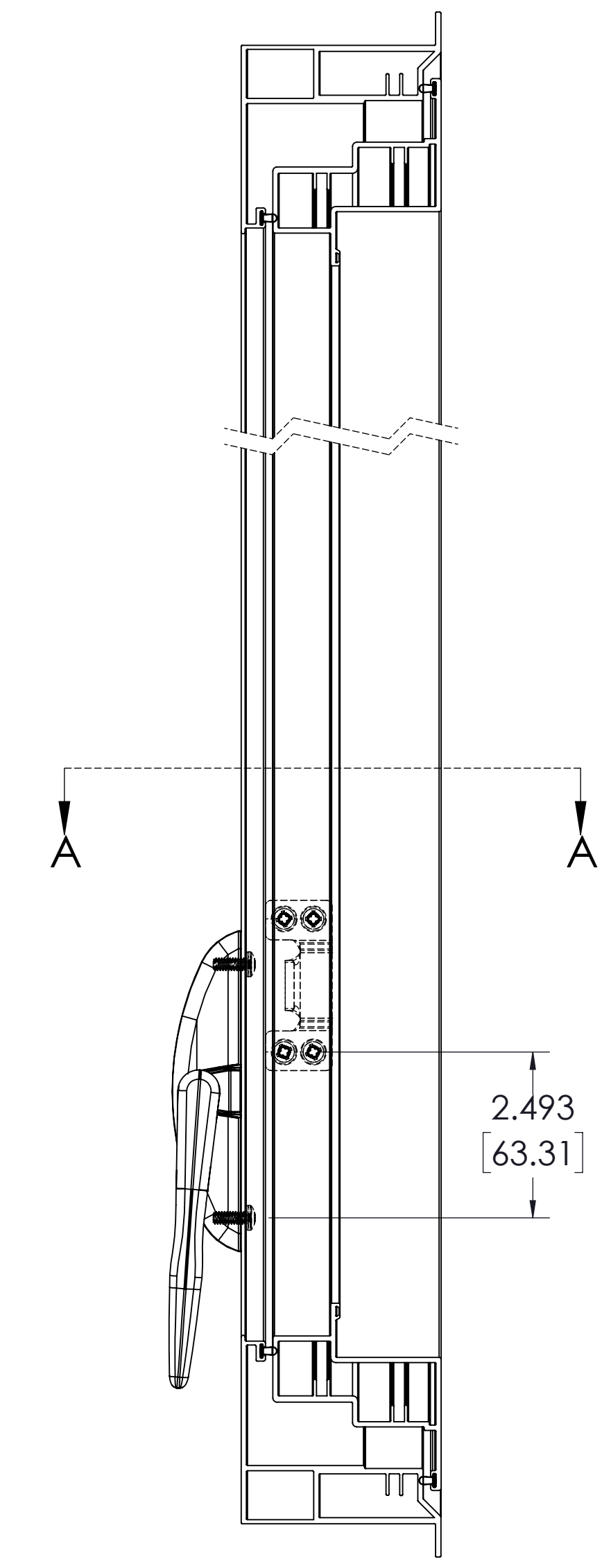

FRAME RELATIONSHIP OF KEEPER TO LOCK

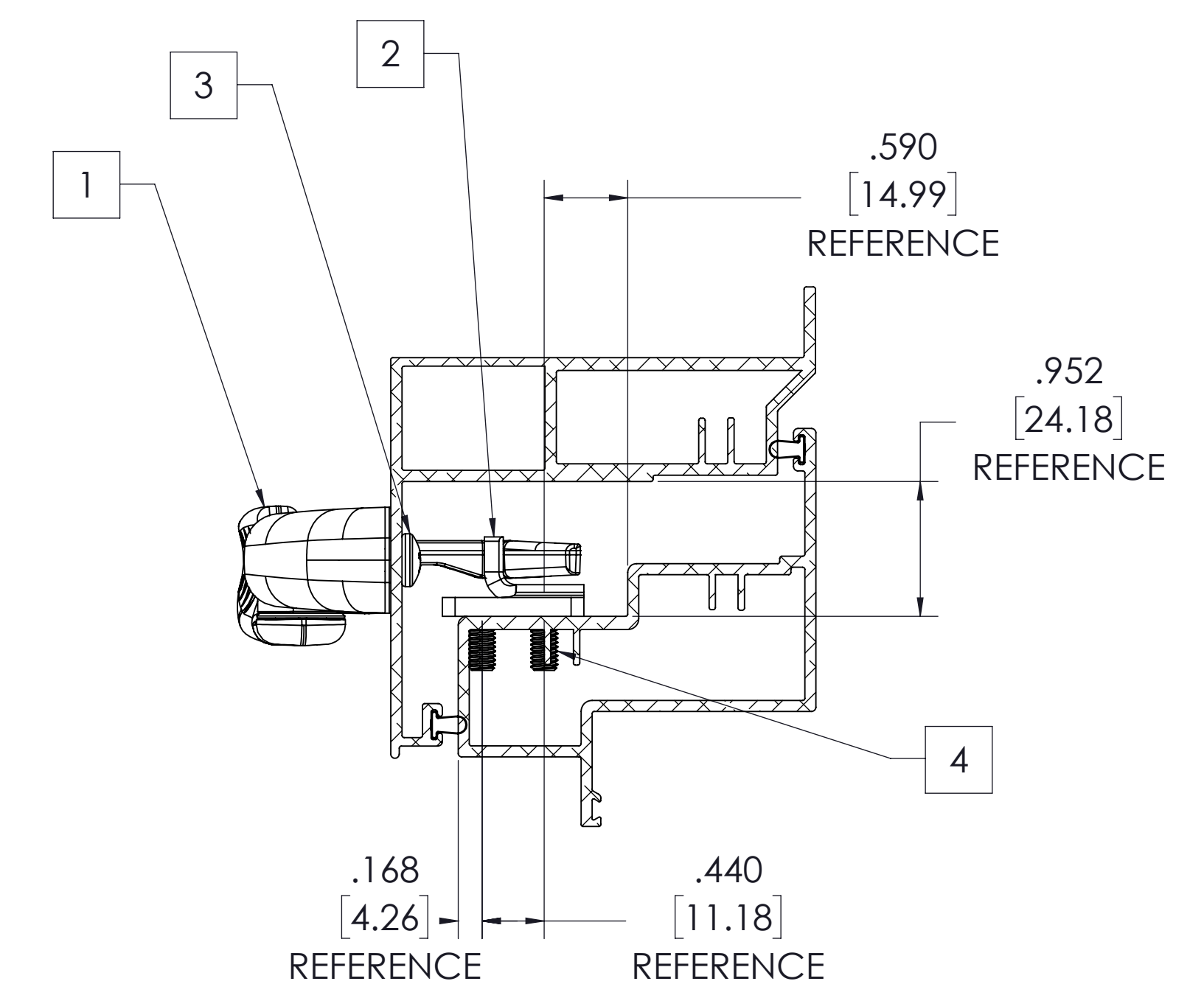

SECTION A-A SCALE 1:1

NOTES:

- 1 ACCURACY OF INDICATED DIMENSIONS IS CRITICAL TO THE FUNCTION OF THE LOCK.
- 2 THIS IS ONLY A GENERIC PROFILE PROVIDED TO HELP GUIDE INSTALLATION AND LOCATION AND MAY DIFFER FROM OTHER CUSTOMER PROFILES.
- 3. MINIMUM WINDOW HEIGHT 16" WITH BUTT HINGES AND 21" WITH 4-BAR HINGE (10").
- 4. IT IS RECOMMENDED TWO LOCKS BE USED IN AWNINGS, ONE IN EACH JAMB.

ITEM NO.	PART NUMBER	DESCRIPTION	QTY.
1	24.51.XX.001	LOCK, CONTOUR SPT W/GASKET	1
2	33703.00.0500	KEEPER, AWNING .090 OFFSET	1
3	19332	SCREW 10-24 X 1/2 F PH PH MS YZ	2
4	N-A	SCREW, 10-32 X 1/2 T23 PH FH MS SS18-8	4

TRUTH HARDWARE MAKES NO WARRANTY OR REPRESENTATION OF ANY KIND, EXPRESS OR IMPLIED, WITH RESPECT TO QUALITY, CONTENT, FORM, PERFORMANCE, FITNESS FOR PURPOSE, MERCHANTABILITY OR OTHERWISE OF THE APPLICATION DRAWINGS PROVIDED. THESE DRAWINGS ARE USED AT THE RECIPIENT'S OWN RISK AND TRUTH HARDWARE HAS AND SHALL HAVE NO RESPONSIBILITY FOR RECIPIENTS, OR ANY THIRD PARTYS, USE OF THESE DRAWINGS OR ANY OF THE INFORMATION CONTAINED THEREIN. THE RECIPIENT AGREES TO INDEMNIFY, DEFEND, AND HOLD HARMLESS TRUTH HARDWARE AND ITS EMPLOYEES AND THEIR SUCCESSORS AND ASSIGNS FROM AND AGAINST ANY AND ALL CLAIMS, SUITS, LOSSES, DAMAGES OR COSTS INCURRED FROM USING THESE DRAWINGS OR ANY CONTENT THEREOF.

**Amesbury Truth**  
 Engineered Solutions. Trusted Results.  
 700 West Bridge Street  
 Owatonna, MN 55060  
 Telephone 507-451-5620

THIS DRAWING IS THE PROPERTY OF TRUTH HARDWARE. THE INFORMATION THEREON IS TO BE TREATED AS CONFIDENTIAL. IT IS NOT TO BE USED, COPIED, OR DISCLOSED TO OUTSIDE PARTIES WITHOUT OUR WRITTEN CONSENT.

DRAWN BY: M. NEFF DATE: 10/2/2022  
 CHECKED BY: MDN SCALE: 1:2  
 PART NAME: CONTOUR SINGLE-POINT LOCKING AWNING

DO NOT SCALE DRAWINGS